



INSTALLATION INSTRUCTIONS

Accessory
FRONT LOWER TRIM
P/N 08P46-STX-200B

Application
2012 MDX

Publications No.
BII 46619
Issue Date
OCT 2011

PARTS LIST

Front lower trim

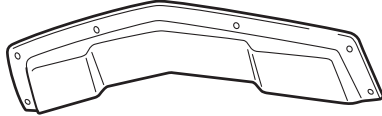

Front lower molding



4 Special bolts, 6 x 24 mm



2 Special bolts, 6 x 40 mm



6 Washers



2 Washer-nuts



4 Rivet nuts



4 Self-tapping screws



TOOLS AND SUPPLIES REQUIRED

- Phillips screwdriver
- Flat-tip screwdriver
- 19 mm Ratchet wrench
- 5 mm Hex bit
- Torque wrench
- 10 mm and 19 mm Wrenches
- Drill
- 3 mm, 7 mm, and 9 mm Drill bits
- File
- Gloves
- Eye protection (face shield, safety goggles, etc.)
- 6 mm Rivet Nut Tool (T/N 07AAE-STX-A100)
- Masking tape
- Duct tape
- Tape measure
- Service Manual

INSTALLATION

Client Information: The information in this installation instruction is intended for use only by skilled technicians who have the proper tools, equipment, and training to correctly and safely add equipment to your vehicle. These procedures should not be attempted by "do-it-yourselfers."

NOTE: Be careful not to damage the front bumper or other surfaces of the body.

1. Lift or jack up the vehicle as described in the service manual.

- Secure the front lower molding to the front bumper with masking tape in the position shown.

NOTE: Check the outside edge of the front lower molding to make sure there are no gaps.

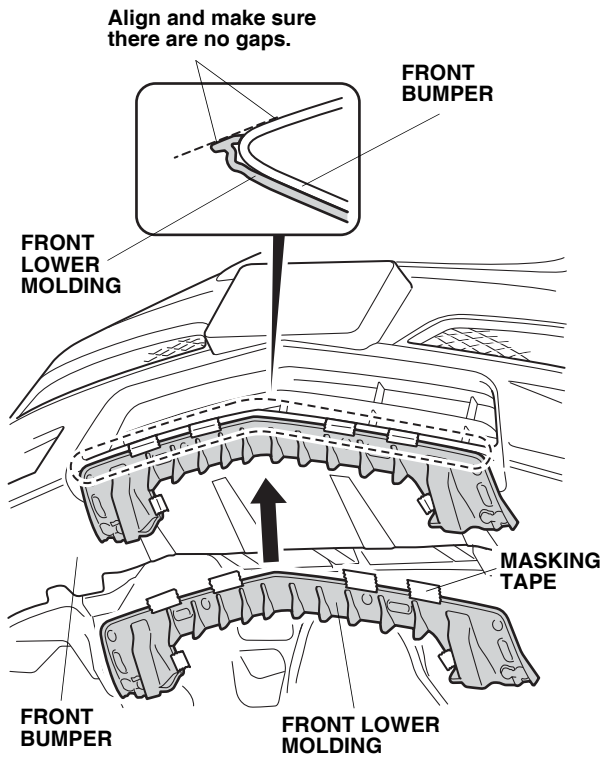

- Wrap duct tape around a 3 mm drill bit 10 mm (0.4 in.) from the tip, or use a drill stop.

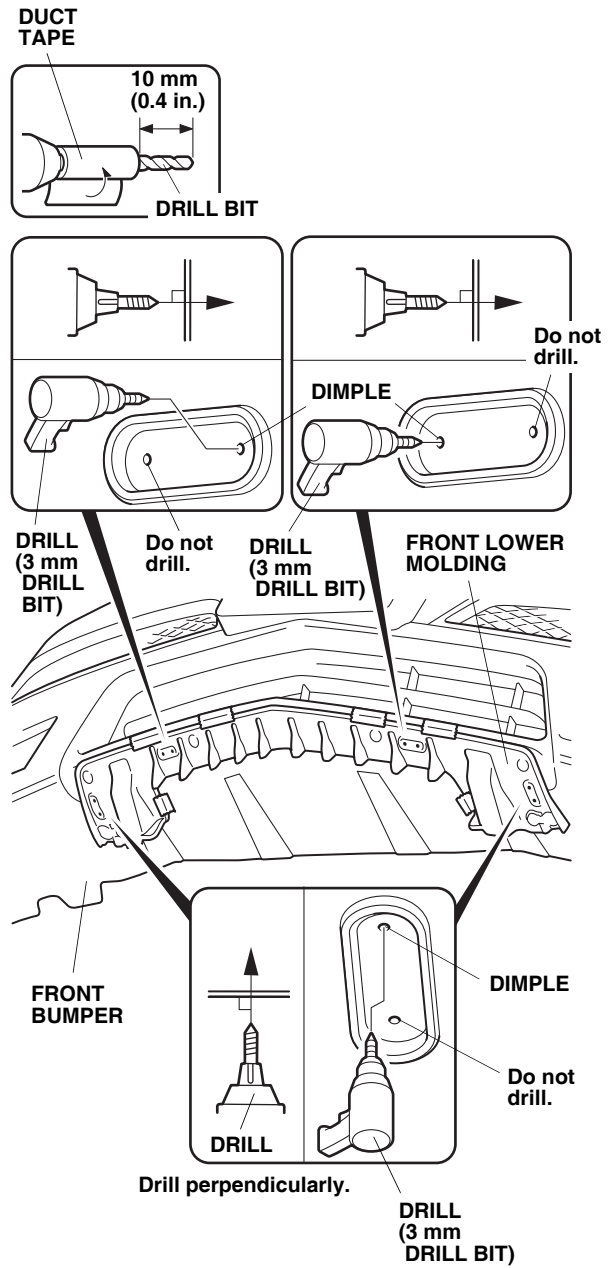

- While wearing eye protection and holding the front lower molding against the front bumper, use a 3mm drill bit to drill a hole through the center of each of the four dimples shown. Remove any burrs from the edges of the holes with a file.

- While holding the front lower molding against the front bumper, install four self-tapping screws. Remove the masking tape attached in step 2.

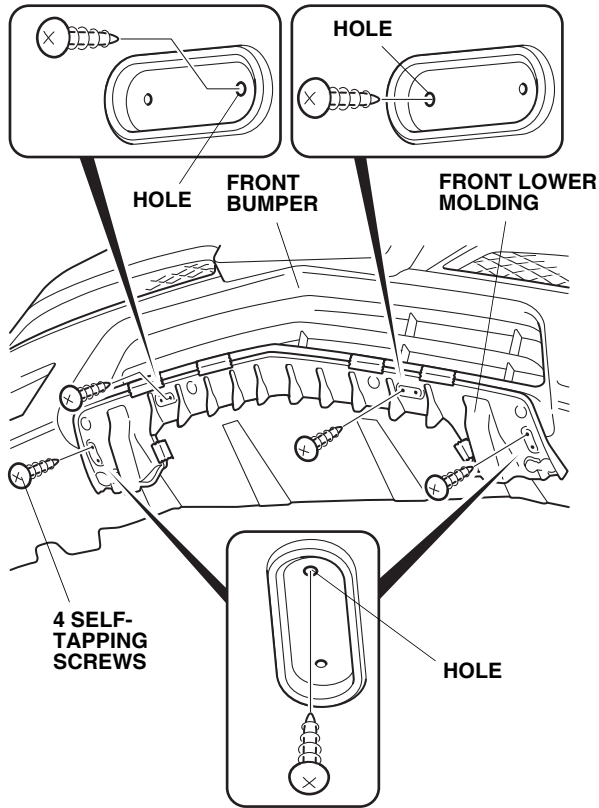

- Push on the outside edge of the front lower molding to make sure there is no gap.

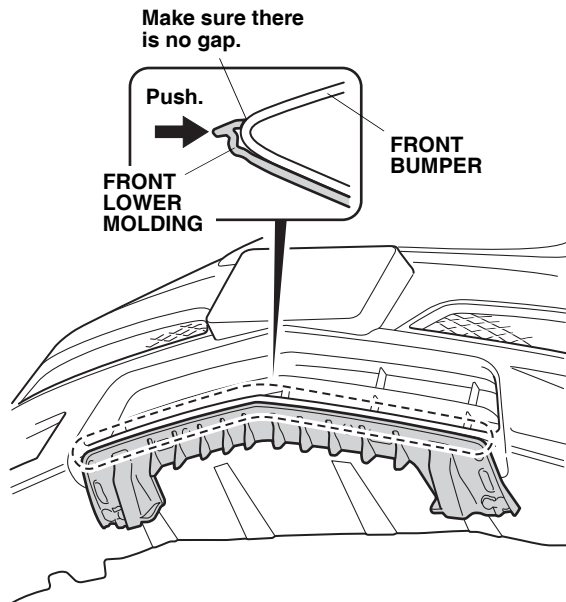

NOTE: If there is a gap to the outside edge of the front lower molding, remove the self-tapping screws and realign the front lower molding. Repeat steps 3 and 4 to drill the four alternate locations, and then reinstall the self-tapping screws in the alternate locations.

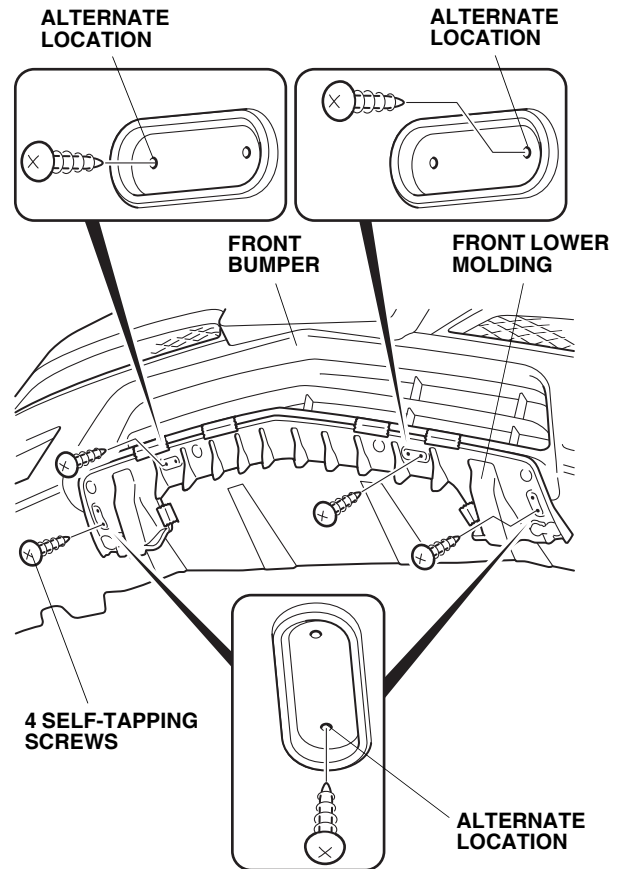

7. Wrap duct tape around a 3 mm and a 7 mm drill bit 10 mm (0.4 in.) from the tip or use a drill stop.

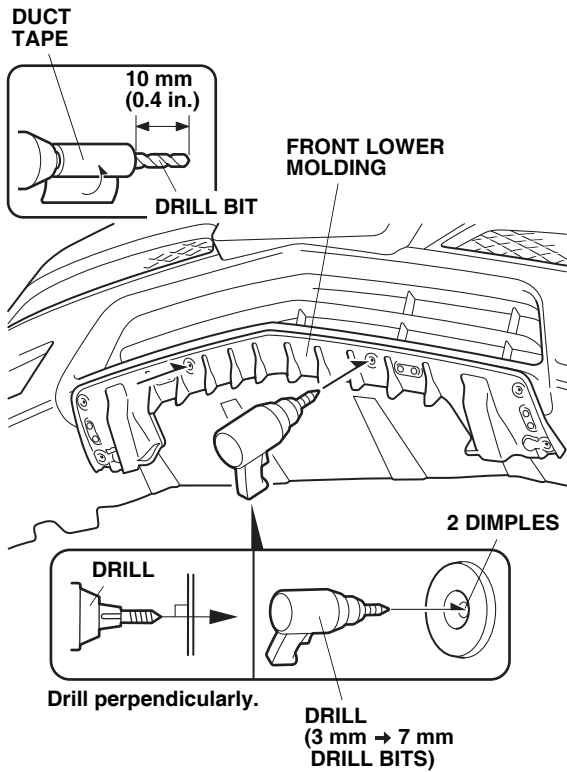

8. While wearing eye protection, drill holes through the centers of the two dimples. First drill with a 3 mm drill bit, and finish with a 7 mm drill bit. Remove any burrs from the edges of the holes with a file.

9. Wrap duct tape around 3 mm and 9 mm drill bits 10 mm (0.4 in.) from the tip or use a drill stop.

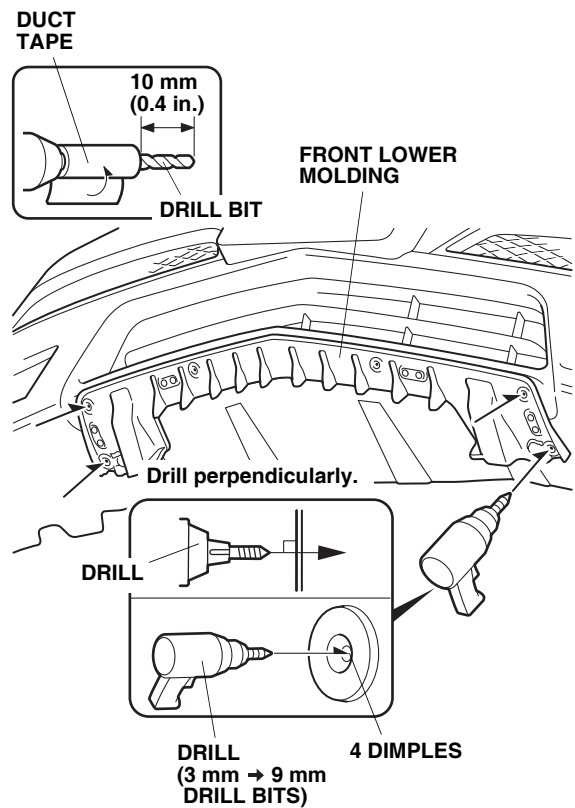

10. While wearing eye protection, drill holes through the centers of the four dimples. First drill with a 3 mm drill bit, and finish with a 9 mm drill bit. Remove any burrs from the edges of the holes with a file.
11. Follow steps 12 through 17 to install four rivet nuts in the holes in the positions shown.

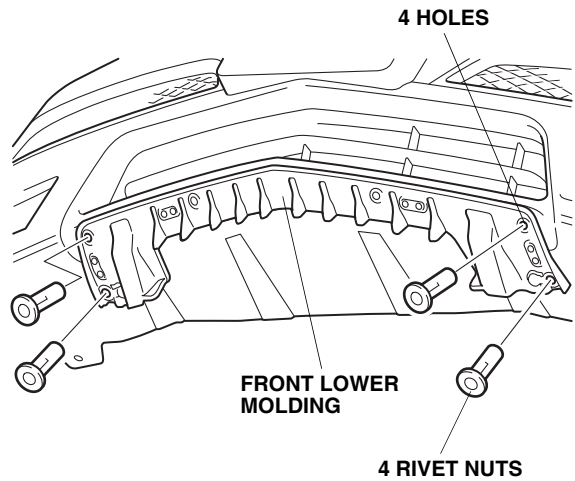

- Turn the nut counterclockwise until the stud is fully extended.

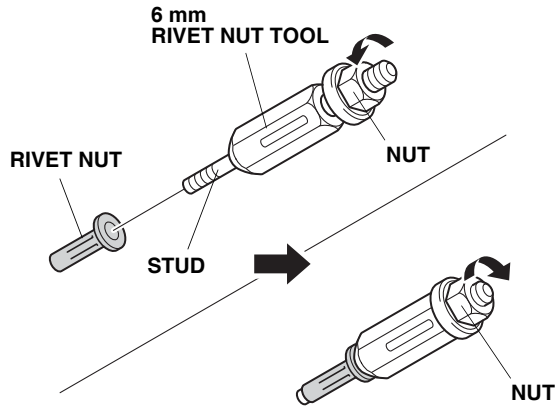

- Thread the stud into the rivet nut.
- Turn the nut clockwise until it becomes tight.
- Insert the rivet nut into the hole. Place a 19 mm wrench on the rivet nut tool body, and hold the nut stationary with a 19 mm ratchet wrench.

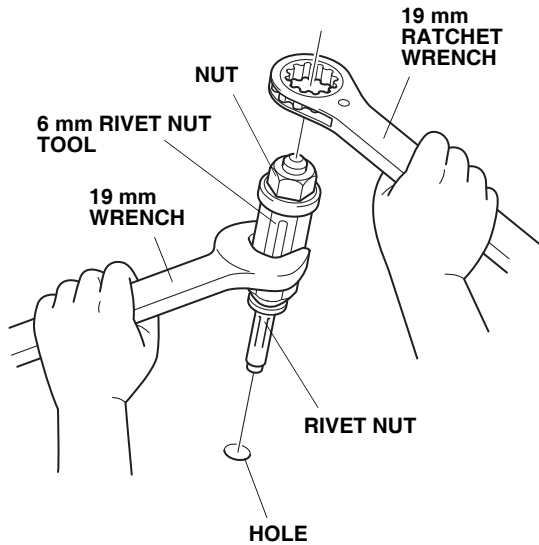

- Turn the 19 mm ratchet wrench clockwise while holding the rivet nut tool perpendicular to the work. Turn the nut until firm resistance is felt. Several turns will be required.

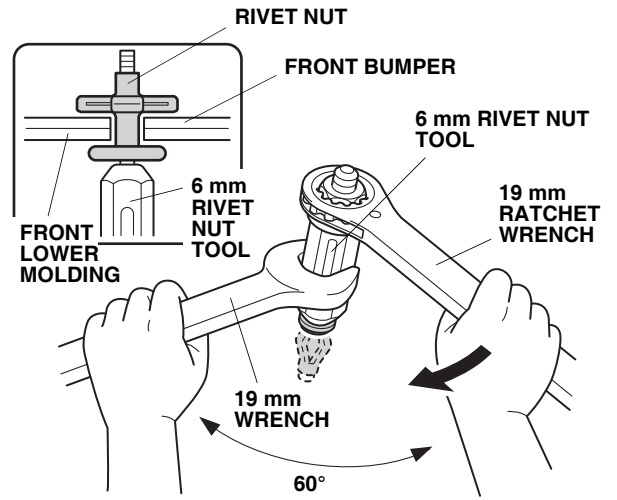

- Remove the rivet nut tool from the rivet nut by turning the tool body in a counterclockwise direction.

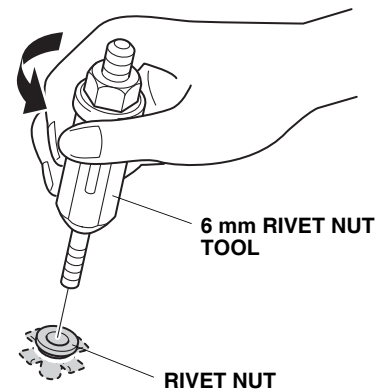

18. Fold down the two hinge spacers on the front lower molding, and secure them with duct tape.

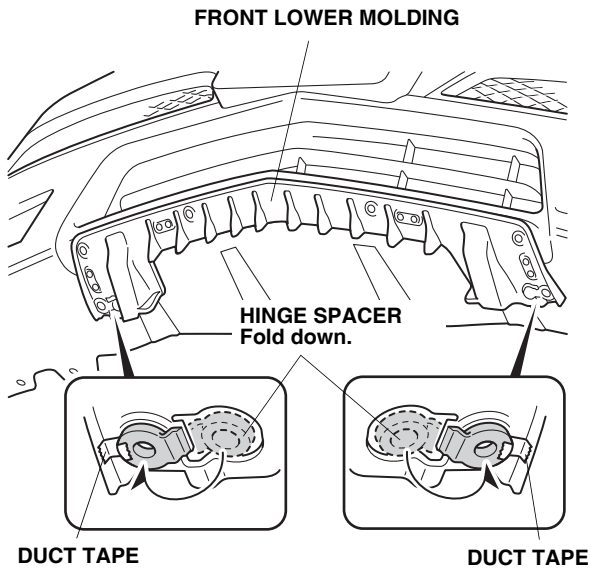

19. Position the front lower trim over the front lower molding, and install four washers, two 6 x 24 mm special bolts, and two 6 x 40 mm special bolts. Do not tighten the special bolts yet.

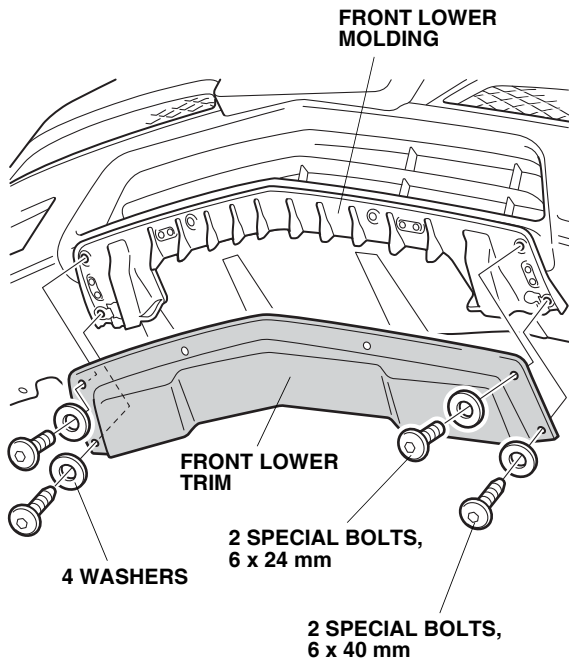

20. Remove the three clips from the hinges on the front bumper.

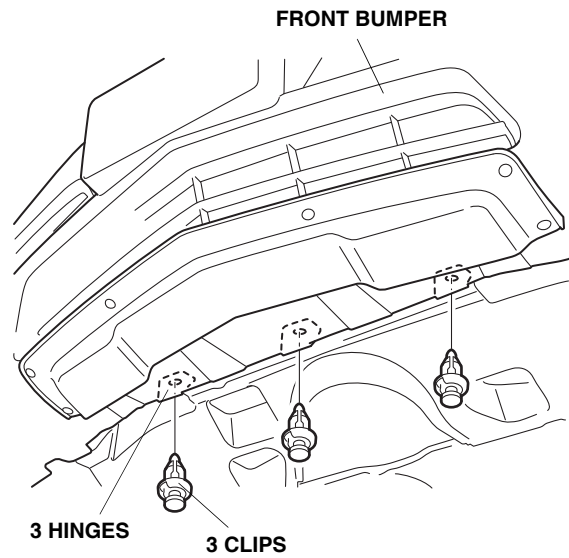

21. While wearing gloves, reach inside and hold the washer-nuts to the inside of the front bumper. Install two washers and two 6 x 24 mm special bolts into the washer nuts. Do not tighten the special bolts yet.

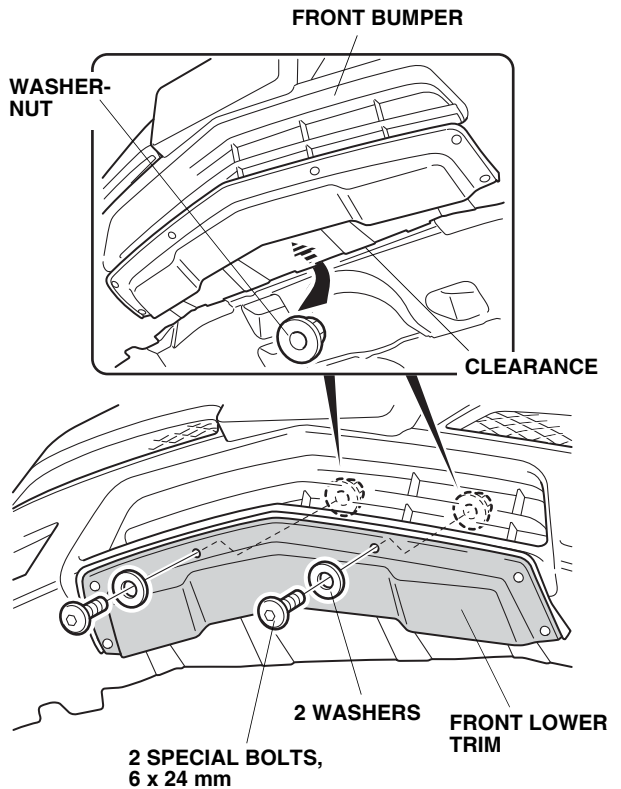

22. Tighten the special bolts in the order shown. Torque the special bolts to 6 to 9 N·m (4.4 to 6.5 lbf·ft).

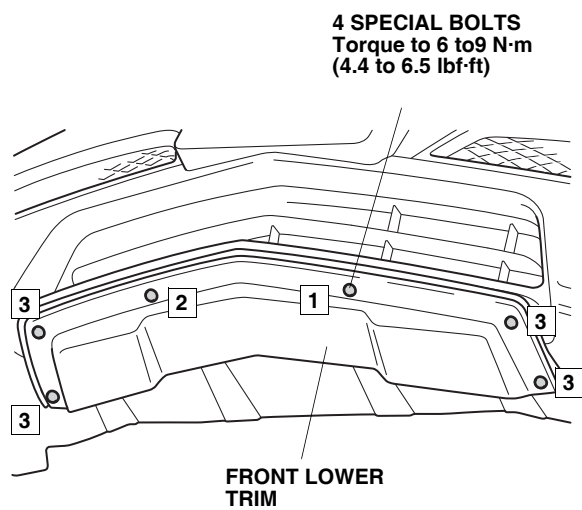

23. Confirm that the hinges are aligned, and reinstall the clips removed in step 20.